

 **LOGOSOL**

USER MANUAL

Ref. no: 0458-395-0641

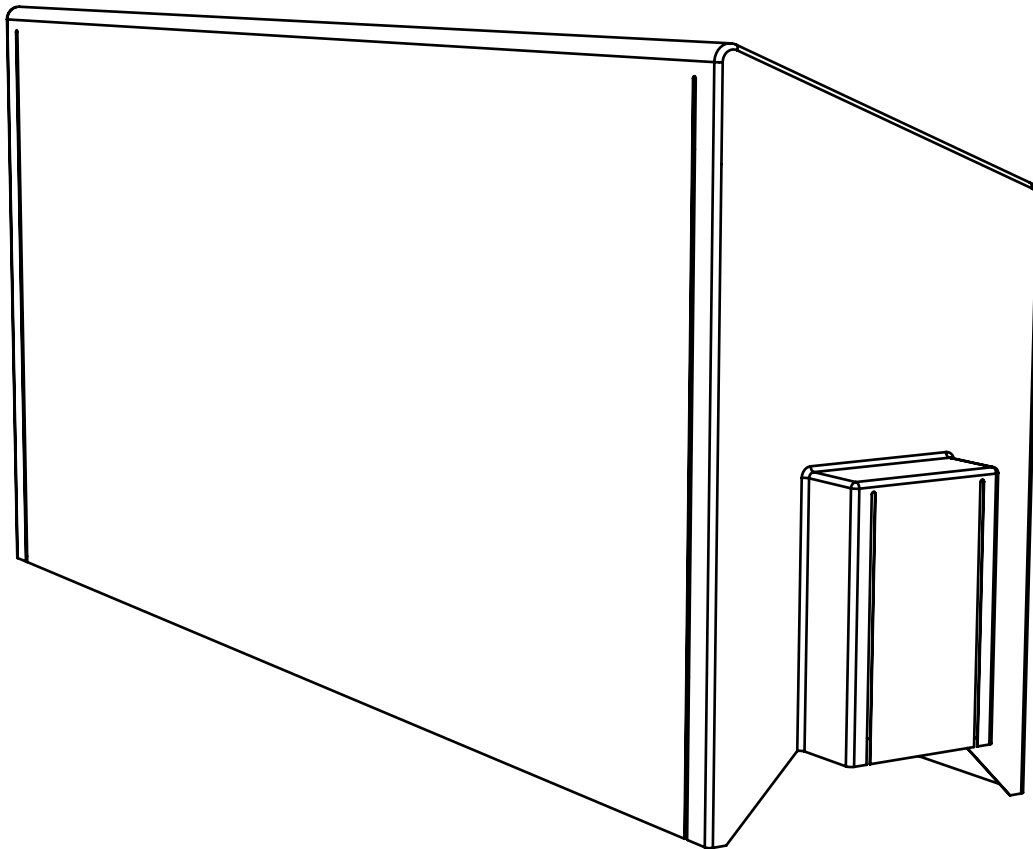

SAUNO DRYING CHAMBER

EN

THANK YOU FOR CHOOSING A LOGOSOL MACHINE!

We are very pleased that you have demonstrated your confidence in us by purchasing this product, and we will do our utmost to meet your expectations.

Logosol has been manufacturing sawmills since 1989. In that time we have supplied approximately 50,000 machines to satisfied customers the world over.

We care about your safety as well as we want you to achieve the best possible results with your equipment. We therefore recommend that you take the time to carefully read this user manual from cover to cover in peace and quiet before you begin using the drying kiln. Remember that the machine itself is just part of the value of the product. Much of the value is also to be found in the expertise we pass on to you in the user manuals. It would be a pity if that were not utilised.

We hope you get a lot of satisfaction from the use of your new machine.

Bengt-Olov Byström

Bengt-Olov Byström
Founder and chairman,
Logosol in Härnösand, Sweden



Read through the user manual carefully and make sure you understand its contents before you use the equipment.



This user manual contains important safety instructions.



WARNING! Incorrect use can result in serious or fatal injuries to the operator or others.



LOGOSOL continuously develops its products.
For this reason, we must reserve the right to modify
the configuration and design of our products.
Document: User manual, LOGOSOL Sauno Drying Chamber
Ref. No. User Manual, English: 0458-395-0641
Text: Martin Söderberg
Illustrations: Martin Söderberg
Last revised: November 2020
© 2020 LOGOSOL, Härnösand Sweden

TABLE OF CONTENTS

Safety instructions	4
Components: Drying chamber	6
Assembly	7
Sauno drying programme	14
CE Declaration of conformity	16

SAFETY INSTRUCTIONS



For your own safety, do not start assemble or use the drying chamber without first having read and understood all the contents of this user manual. Do not let persons who have not read the instructions use the drying chamber.



If used incorrectly, the drying chamber can cause injury and material damage.



Do not connect the electric power until you have installed the drying chamber according to these instructions.

KEY TO SYMBOLS



This symbol means 'WARNING'. Pay particular attention where this symbol appears in the manual text.



This symbol is followed by instructions that must be observed. Pay particular attention where this symbol appears in the manual text.

GENERAL

The drying unit may only be used for drying wood in a chamber intended for this purpose.



In this user manual **"cut the power"** means that the cable that supplies power to the equipment should be disconnected from the mains and placed such that no unqualified person can reconnect it. Wait until the drying unit has cooled completely.

Cut the power:

- before touching the part of the drying unit that is on the inside of the drying chamber.
- before opening any of the inspection hatches on the drying unit.
- before cleaning or other maintenance.
- before moving the drying unit.



Risk of burn injury.



The drying unit has hot heating elements. It must not be started until it is correctly installed in a drying chamber, and the drying chamber is closed. Never put your hands inside the drying unit unless the power has been cut off.

SITING



Risk of personal injury



Risk that the stack of wood falls on someone.



Risk of fire if the drying unit or the stack of wood falls/tips over



Risk that an empty drying chamber tent falls/tips over due to strong winds



Follow the instructions below:

- Set up the drying chamber on a flat surface that is firm enough to hold the weight from the load.
- The wood should be stacked in a stable way. Certain movements can occur in the stack when the wood is drying.
- The drying kiln should be placed at a secure distance from surrounding buildings and other objects that can be damaged in an event of fire. Safety distance from the drying chamber and drying unit to any combustible material should be at least 5 m. We recommend you to contact your local fire protection authority for guidance if you are unsure.
- For maximum fire and electrical safety, earth leakage circuit breakers must be used.
- Ensure that the air in the drying chamber can circulate and that the wood inside the chamber is not closer than 5 cm to the drying unit.
- Place the drying kiln such that the start / stop button is not blocked.
- Never step on the power cable of the drying unit. The cable should be protected against accidental damage.
- If the drying chamber is empty it must be secured to avoid it blowing over due to strong winds. The easiest way is to leave a certain amount of wood inside the drying chamber to give it stability.

BEFORE CONNECTING THE EQUIPMENT TO THE MAINS

Check that:

- the fan wheel can rotate freely and that no loose objects are left inside the drying unit.
- all inspection hatches are correctly fitted.
- the connection cable that powers the drying unit is in good condition.
- all visible fasteners are tightened. They might need additional tightening after transport.
- the labelling of the drying unit matches your electrical connection.
- Check the function of the thermostat.

ELECTRICAL SYSTEM



Risk of electric shock



The electrical system may only be opened by a qualified electrician. Always cut the power to the electrical system before it is opened or servicing is carried out.



Risk of accumulating condensed water inside the junction box due to large variations in temperature and extreme weather.



Cut the power and let a qualified electrician check that the junction box is dry.

MAINTENANCE

After every fifth drying cycle or as needed:

- Cut the power.
- Remove the drying unit from the drying chamber.
- Open the inspection hatches of the drying unit and clean heating elements, the cooling air intake of the electrical motor and the fan wheel with a soft brush, soap and water. Make sure that all the water has dried up before you re-install the inspection hatches and connect the power cable to the drying unit
- Only use original parts supplied and approved by Logosol for the purpose. Use only purpose made original parts from Logosol. **After service, the drying unit has to be restored to its original design.** All inspection hatches and covers must be correctly installed before the drying unit is taken into use. The drying unit may not be modified or rebuilt in any way.
- The warning labels on the machine is for your and others safety. Damaged or illegible labels must be replaced.



6200-000-0020

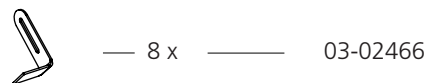
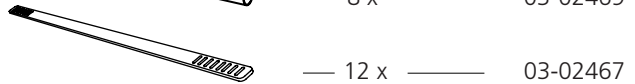
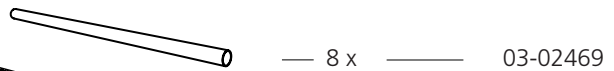
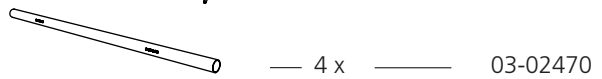
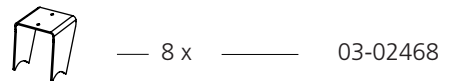
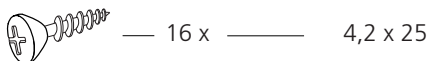
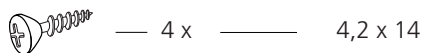
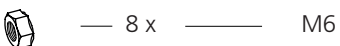
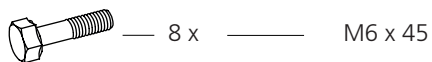
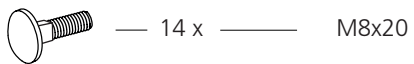
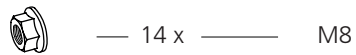
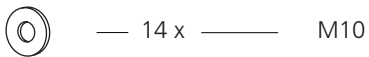
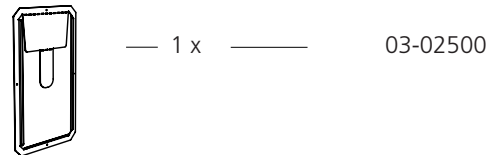
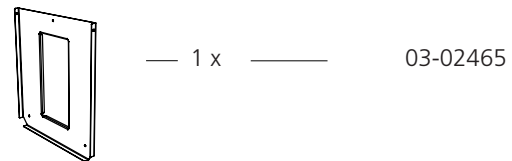
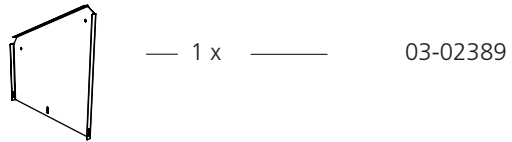
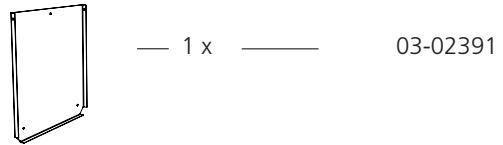
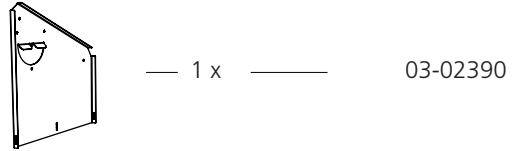
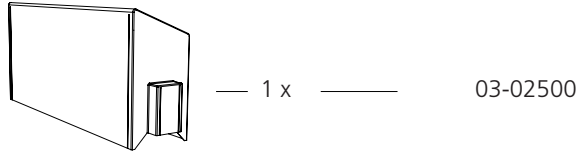
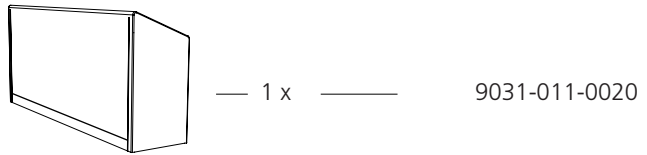
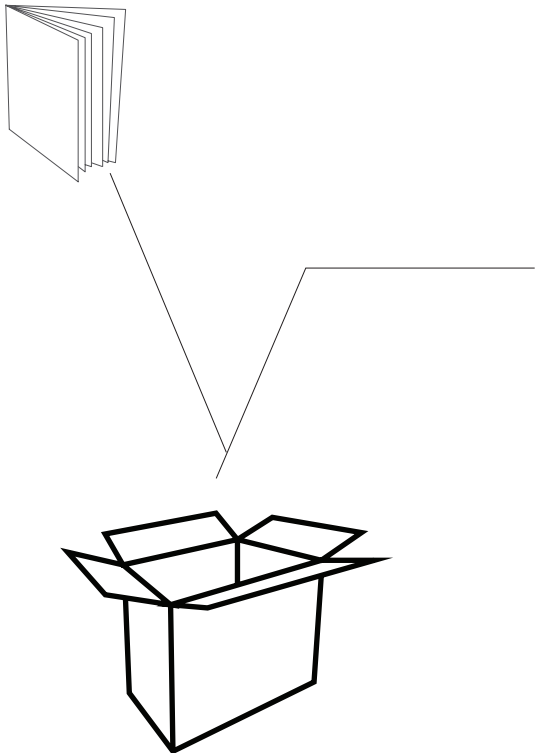

BOLTS & NUTS

Definition of fasteners.

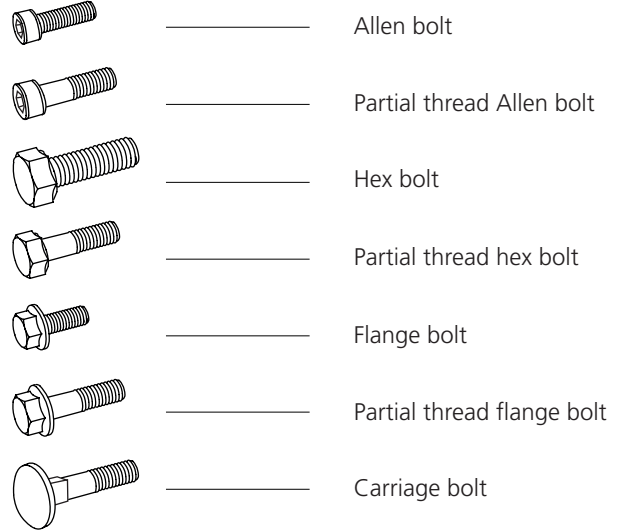
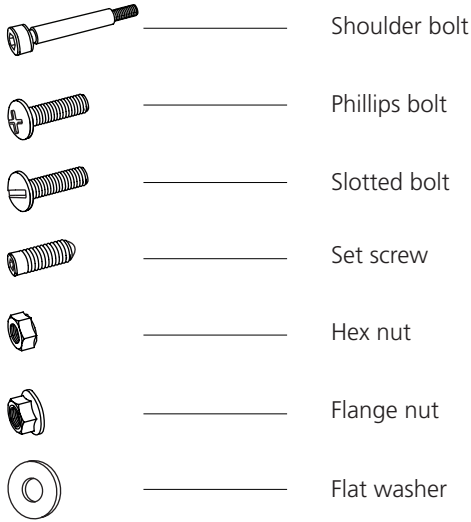

ADDITIONAL SYMBOLS

The following symbols are used as supplements to the symbols above to describe the design or function of the fasteners.





DIAMETER/LENGTH

The size of a fastener is written as a diameter measurement **(M)** ISO 68-1. For bolts, this is followed by a length measurement. The length of the bolt is measured from below the head to the tip of the bolt.

(Diameter) **(Length)**
 M8 x 20

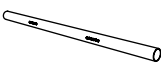
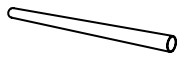
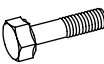

6200-000-0020

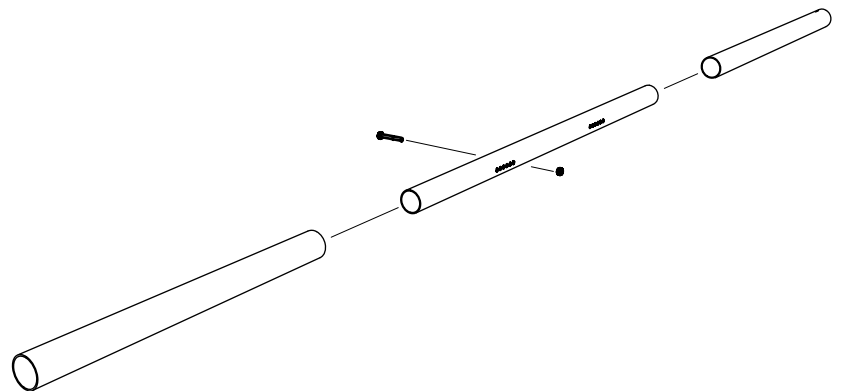

-  - 4 x — 03-02470
-  - 8 x — 03-02469
-  - 4x — M6x 45
-  - 4x — M6





6200-000-0020

1

-  - 6x — M8x 20
-  - 6x — M10
-  - 6x — M6

03-02389

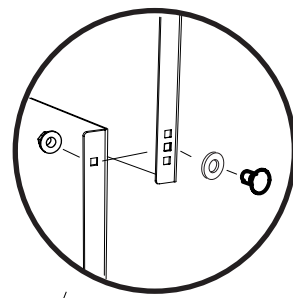





03-02390

03-02465

03-02391

2

-  - 8x — M8x 20
-  - 8x — M10
-  - 8x — M6
-  - 8x — 03-02466

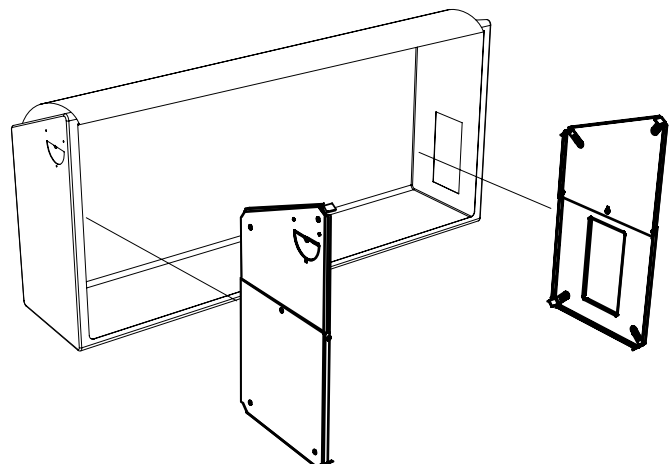
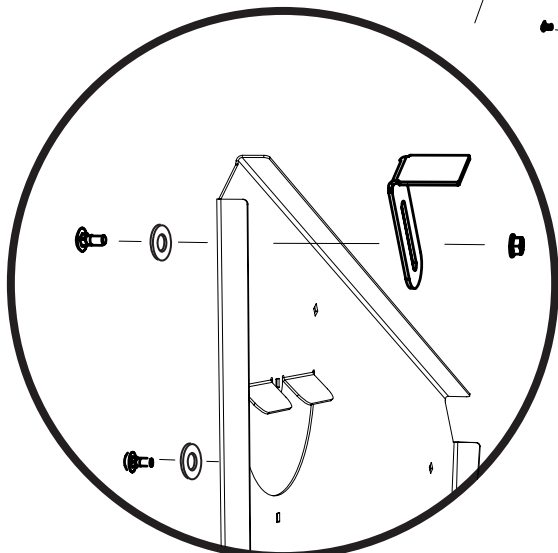
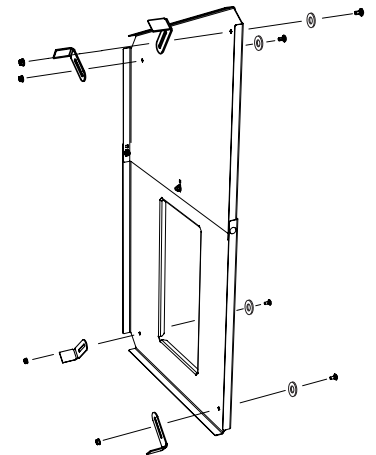
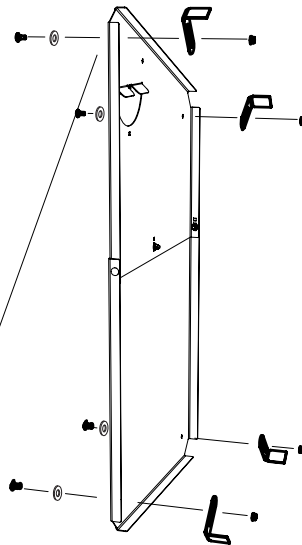



6200-000-0020

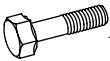

- 2x — M6x 45



- 2x — M6

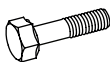
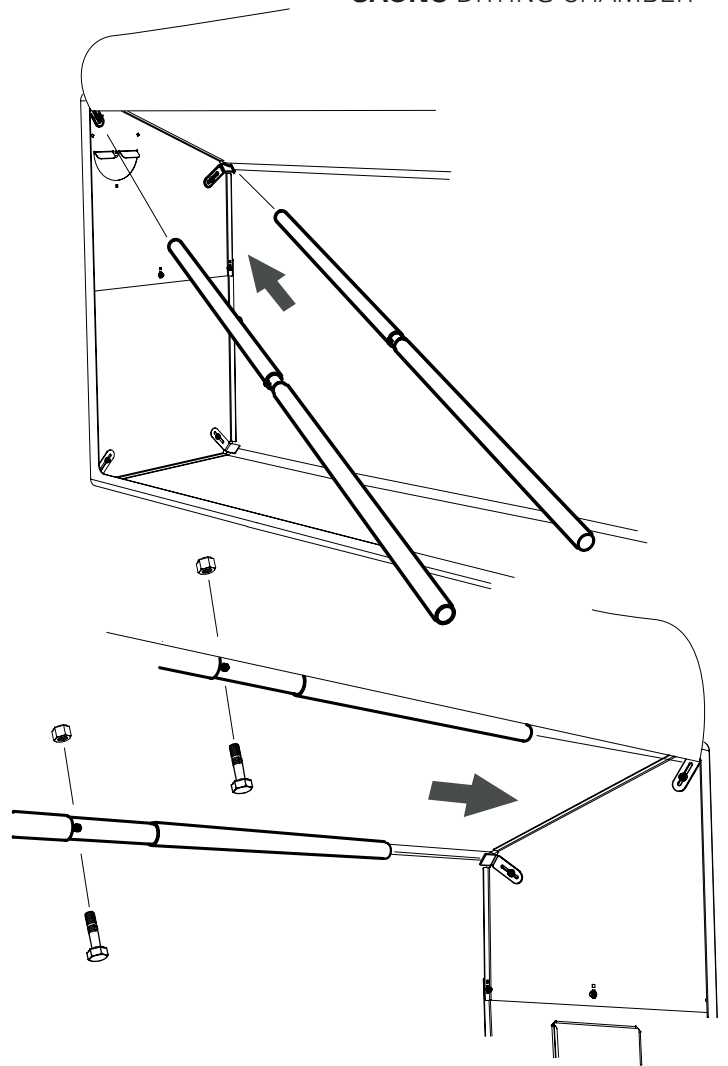

- 2x — M6x 45



- 2x — M6

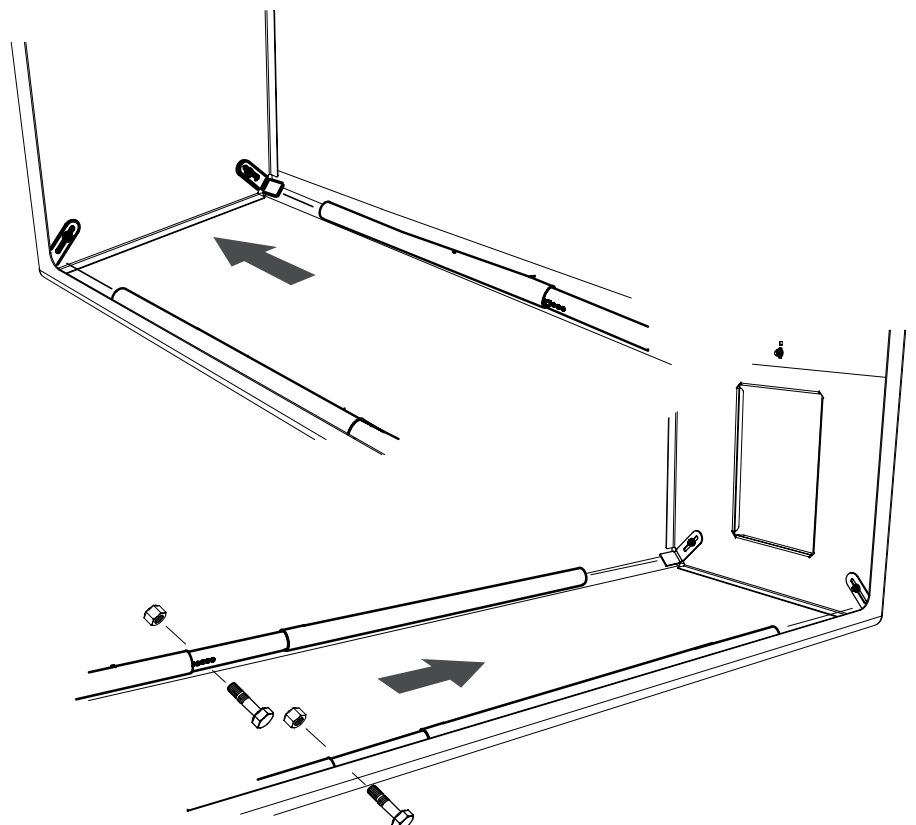



6200-000-0020

5

Mount the laths on the top struts. These laths are mounted from the inside of the drying tent and are folded by hand around the struts. Start from one side side of the drying tent and place the laths with about 25 cm spacing between them. That will prevent the frame struts from bending.

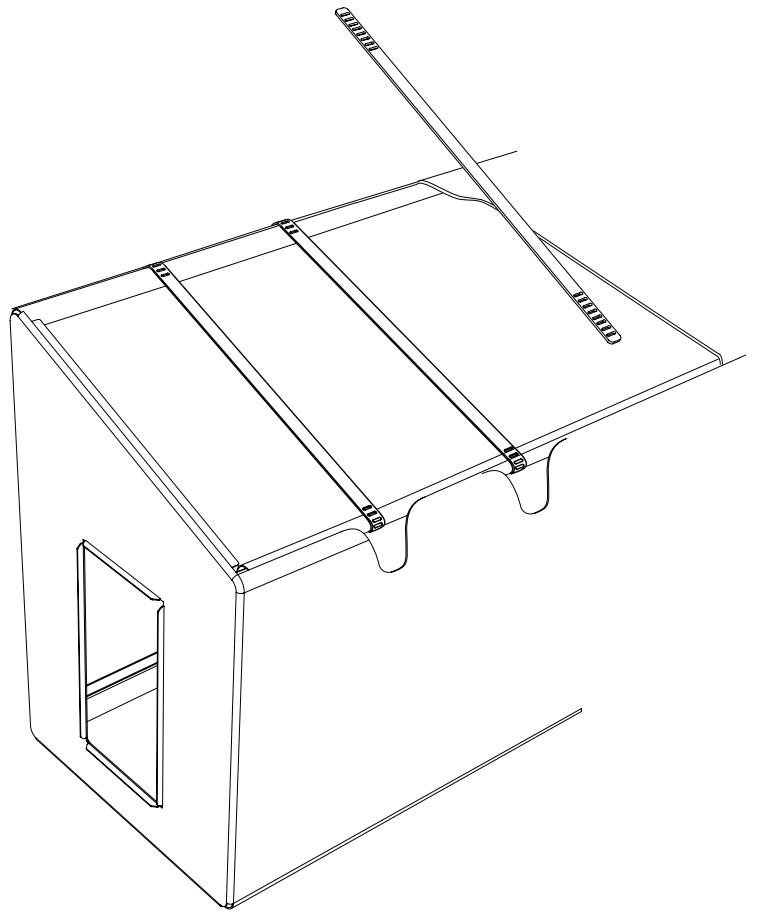

- 12x — 03-02467

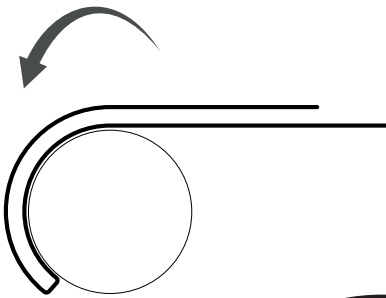
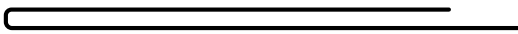

6

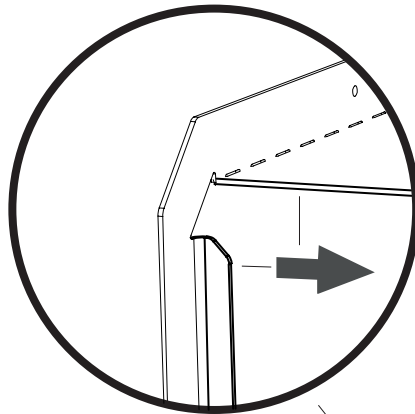

Note that both bendings of the plate should point in the same direction.

03-02500

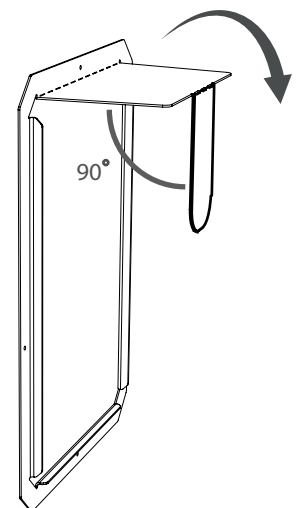
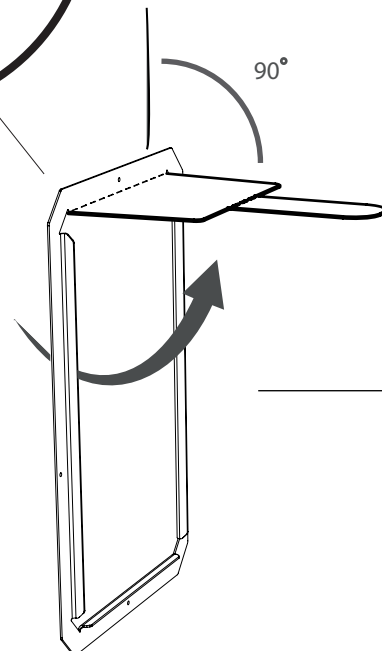
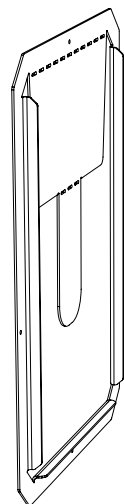



6200-000-0020

7

Use a pair of scissors and cut a hole in the outer tent to enable the installation of the drying unit. Fold the corners around the inside of the hole in the tent side plate.

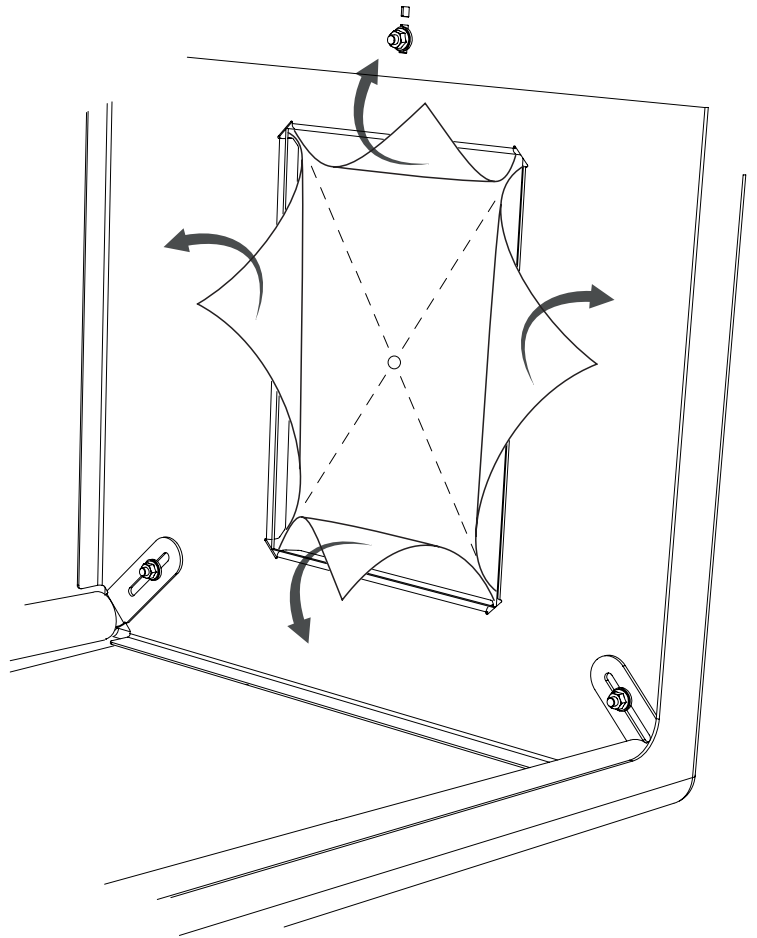
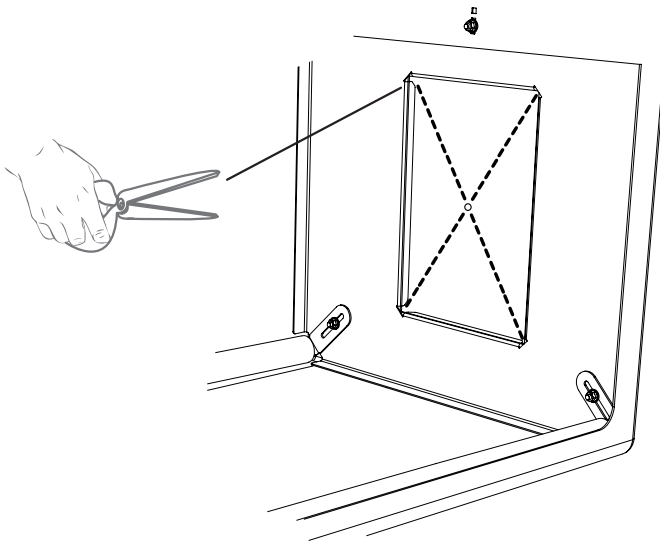

8

Fit the drying unit and safety plate in the cut hole in side of the tent. Make sure that the drying unit clamps against the fabric corners, which are folded on the inside of the drying tent.



— 4x — 4.2 x 14

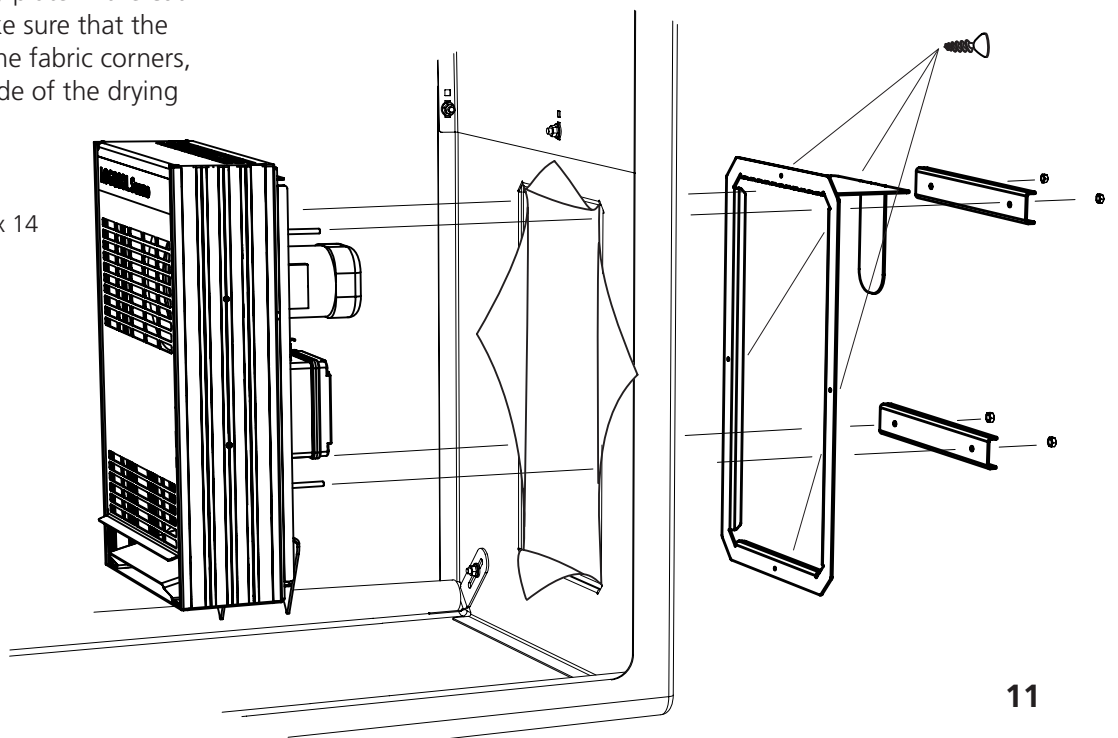



6200-000-0020

9

Take a board that is 50 mm x 100 mm and cut four pieces that are 670 mm in length. Fit these boards to the feet for the lower struts.

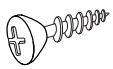

— 16x — 4.2 x 25

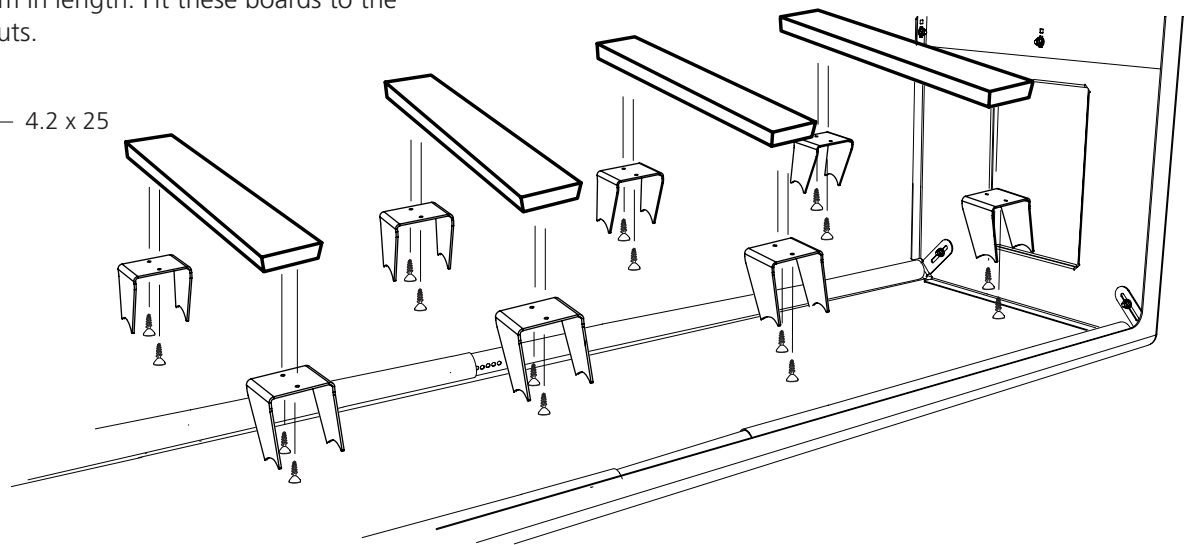

10

Use the tent side plate with the ventilation hole as a template when you make the hole for the air vent. Note that you have to make a hole in the fabric of both the inner and outer tent.

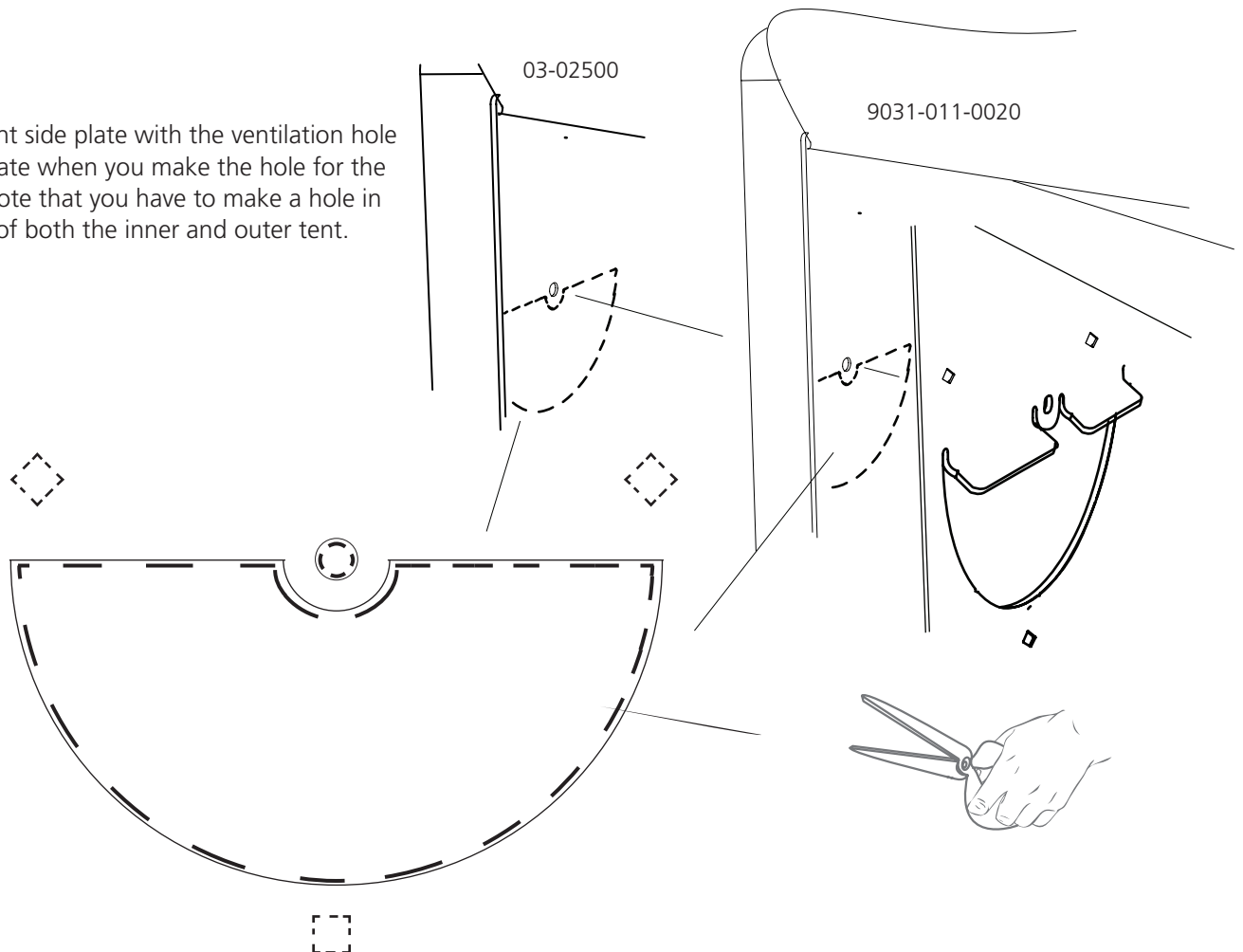



6200-000-0020

11

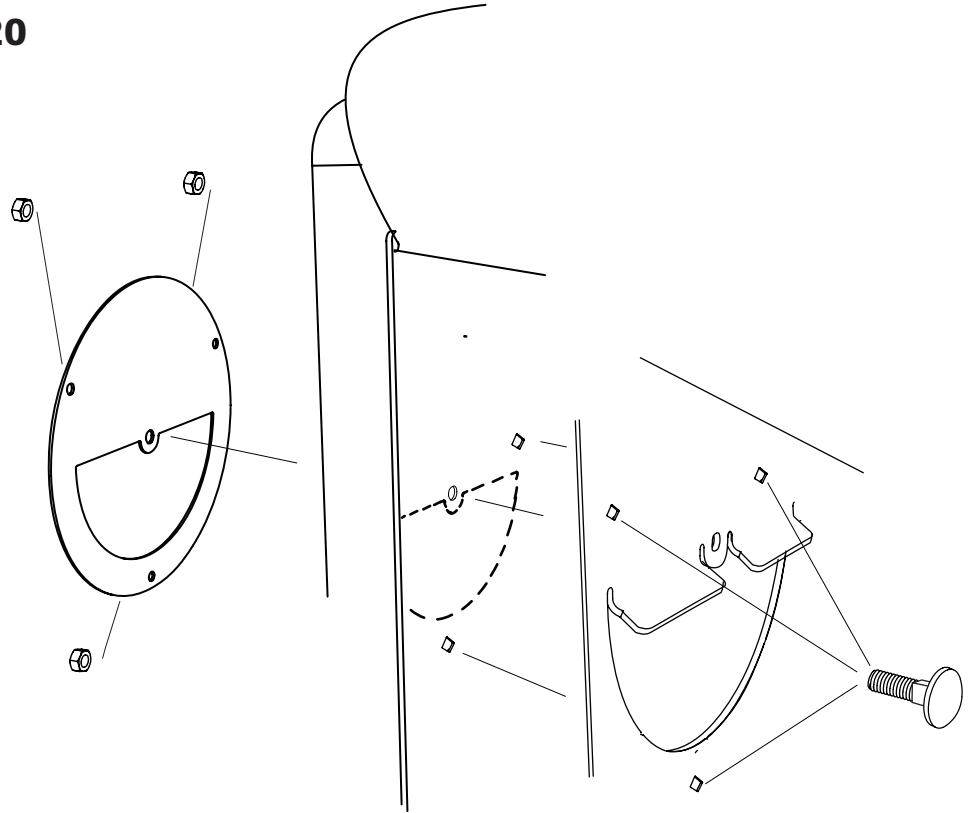

12

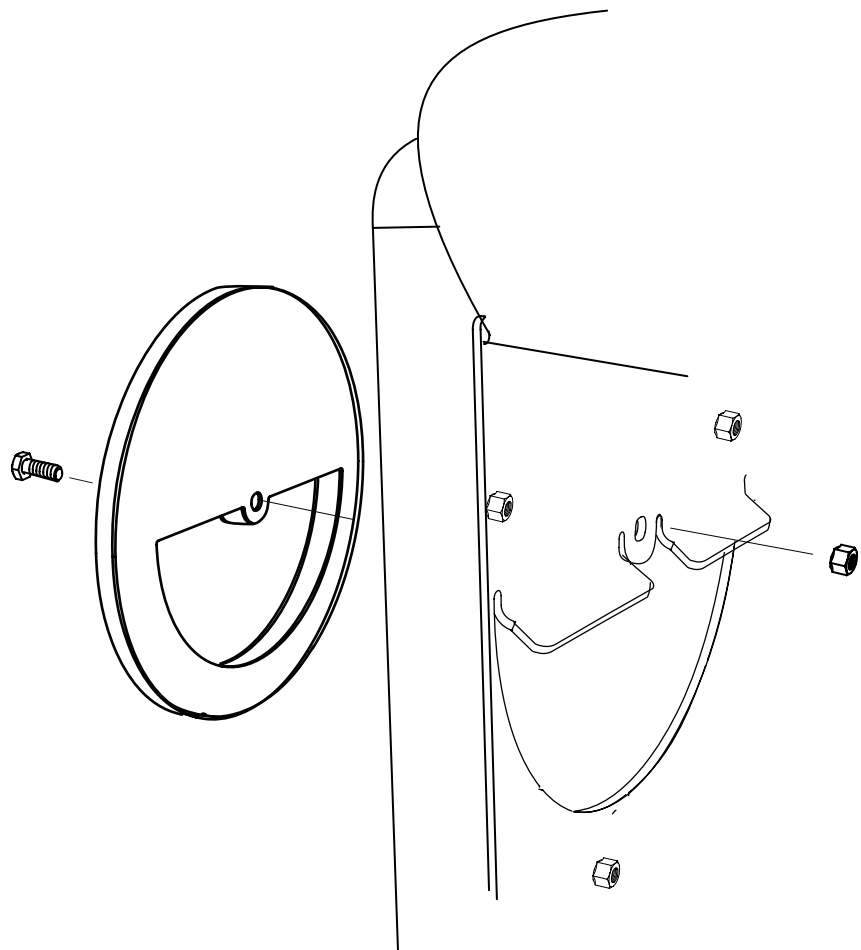

SITING

Place the drying chamber on a stable and flat surface that can hold the weight when the drying chamber is fully loaded with wood. The foundation can be built of wood, preferably with a layer of insulation boards, e.g. styrofoam, to make it more energy efficient.

In a part of the drying process condensation will occur and you will get water in the bottom of the drying chamber. To save energy and shorten the drying process the foundation underneath the drying chamber can be adjusted so it is leaning about 2 degrees near the corner that is furthest from the drying unit. Make a 5 mm drainage hole in that corner and make room underneath the drying chamber so the water can infiltrate into the ground.

The drying chamber should be placed outside and at a safety distance from other buildings. The WDU drying unit should be protected from water and other precipitation. This is best achieved with the Logosol drying chamber that has an outer cover which protects it. Be aware that wood with a high moisture level that is heated can often have a strong smell and that large amount of steam is ventilated out from the drying chamber.

COLOUR CHANGES

At increased temperatures slight colour changes in the wood occurs. Timber with a large amount of sapwood and timber with a lot of knots (especially dry knots) darkens more easily. But there are also benefits with high temperatures, especially when it comes to furniture timber. High temperatures force out resin from the wood, which reduces the risk of later resin bleeding. The colour changes that occur in a Sauno wood drying kiln are usually minor. If you are unsure of what colour changes there will be, it can be a good idea that you first dry a smaller amount of wood as a test. For hardwood, colour changes that come when using a wood drying kiln are usually desirable. Today, most of the modern drying plants use temperatures between 70° and 110°C. The Sauno kiln uses a maximum temperature of 75°C.

STACKING THE TIMBER

The timber should be stacked such that the drying unit is able to blow the circulating air under the timber stack. Place the timber on the bed using spacers between each layer. The spacers should be at least 15 mm thick and placed above each other between the timber layers.

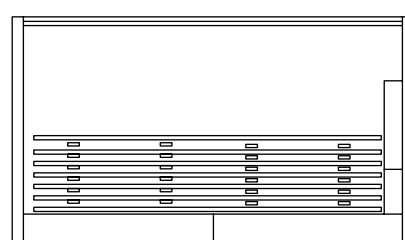
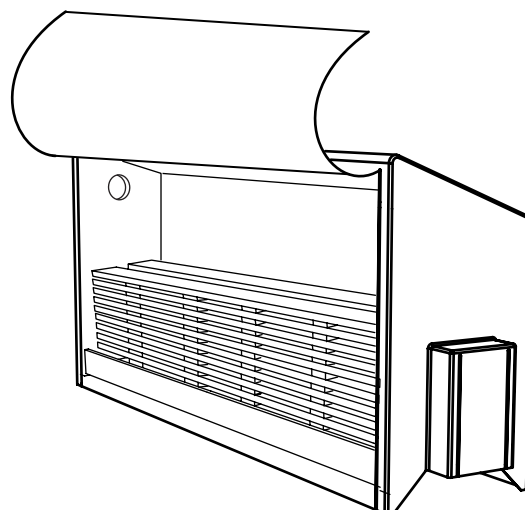

SAUNO DRYING PROGRAMME

DRYING TECHNIQUE

The Logosol WDU kiln uses a relatively low temperature but with high circulation, which gives an energy efficient process. The low temperature used will also give minor colour changes to the wood and reduces the occurrence of sap and resin bleeding. The Logosol drying chamber should not be used at temperatures below 0 degrees C.

PREPARATIONS

Close the drainage hole so the water stays inside the drying chamber. If the wood is green you usually do not need to add any water into the drying tent. However, it is a good idea to pour about 1 litre of water into the drying chamber regardless.

The ends should be sealed with a linseed oil paint. The reason for that is that the ends will dry evenly with the rest of the board. If you do not seal the ends you will get more cracks because they will dry faster than the rest of the board.

Oak and chestnut contain tannic acid and we recommend that they should be air-dried for one year before they are dried in the kiln to avoid corrosion on the drying unit.

DRYING PROCESS

You can open the drying chamber to inspect and measure the moisture level. Open the drainage hole during this process. Set the thermostat to 40°C. Open up both vents $\frac{1}{4}$. Check at least once a day that it feels damp around the edge of the outlet air vent. If not, close the vents slightly more. If it is damp around the vent, you know that the humidity inside the kiln is sufficiently high for making the water in the wood travel from the inside to the outside. It usually takes 2-4 weeks before the wood is dry. Use a moisture meter to measure the process and see when you have reached a desired moisture content. Let the wood rest indoors for 1-2 weeks before using it. This gives the wood an even moisture content.

Eco-advice: If you are not in a hurry we have a good advise to give. After two weeks of running a high temperature, lower it to 25°C and keep the fan running. It can take a bit of time for the moisture to even out in the wood and during that time you will save some energy by lowering the temperature. Run it on this temperature for a couple of weeks before you increase it again and continue on a high temperature until the wood has reached a desired moisture content. After the drying process has been finished you can leave the stack inside the drying chamber and use a very low or no heating at all. Leave the vents open and the fan running. If the fan is turned off the risk is that mold/fungus will start to grow on the surface of the boards.

STEAMING PROCESS

Close the drainage hole in the drying chamber so all the water stays inside. If the wood is green you normally do not need to add any water. However, we recommend that you pour about 1 litre of water over the wood in order to reach 100% humidity quickly. Close the drying chamber and the vents. Set the thermostat to 50°C. Steam the wood for at least 48 hours or until the temperature in the drying chamber has stopped increasing. If the outdoor temperature is cold the temperature in the drying chamber might stabilize just below 50°C.



EU declaration of conformity

LOGOSOL AB,
Fiskaregatan 2
S-871 33 Härnösand, Sweden
Phone: +46 611 182 85,

herewith declares that the **Sauno Drying Chamber** has
been manufactured in conformity with:

Machinery Directive 2006/42/EG, EMC Directive
2004/108/EG and LVD Directive 2006/95/EG.

Mattias Byström, Product Manager, is responsible for
the technical files.

Härnösand 2020-10-21
Mattias Byström, CEO

LOGOSOL

LOGOSOL SWEDEN

Fiskaregatan 2, S-871 33 Härnösand, SWEDEN
Phone: +46 611 182 85 | Fax: +46 (0)611 182 89
info@logosol.com | www.logosol.com